

# Series HB Solid Brass Cylinders

*For General Industrial Use in most Environments*

*200 PSI Pneumatic*

*500 PSI Hydraulic Non shock*

*3/4", 1", 1 1/8", 1 1/2", 2" Bores*

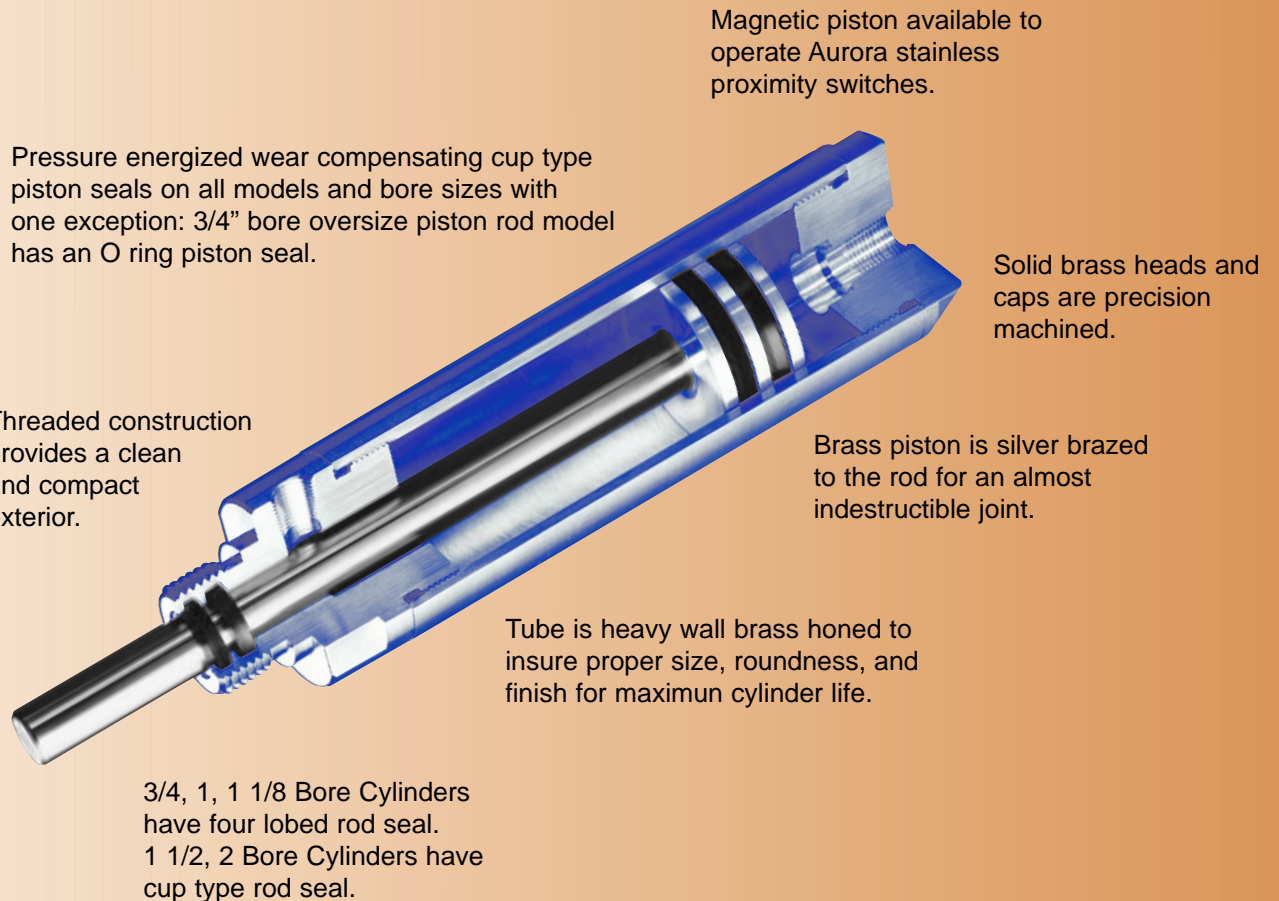

*A natural choice where moisture is a problem .*

# ADDITIONAL DESIGN FEATURES

## SHOCK PADS

Reduce noise and fatigue problems such as rod breakage with energy absorbing shock pads. Add 1/4" to the cylinder length for each pad. For pneumatic use only to 180°F.

## ROD WIPERS

Prolong the life of cylinders operating in dirty environments by adding rod wipers. Polyurethane or Viton wipers are wear compensating and effectively prevent damaging contaminants from entering the critical rod seal/rod bushing area. Limited availability.

## SEAL COMPOUNDS

Standard cylinders contain buna n (nitrile) seals and polyurethane wipers which are compatible with most lubricants and fluids, and can withstand temperatures from -40° to +200°F.

Viton seals and wipers may be ordered for temperatures ranging from -10° to +400°F and for added chemical resistance.

"Long Life" seals will provide significantly increased service life due to their excellent abrasion resistance. Fluid compatibility is identical to buna n seals and their effective temperature range is +20° - +200°F. Long life rod seals are standard on all 3/4, 1, 1 1/8" bore cylinders.

## HYDRAULIC SEALS

Rod seal weepage can be substantially reduced by specifying polypak\* rod seals. They are available on all 1 1/2 and 2" bore cylinders. For availability on other bore sizes consult factory.

## HARD CHROMED PISTON ROD

The standard rod in all HB cylinders is ground and polished type 303 stainless steel. Hard chrome plated steel rods are available. The plating gives the rod a very hard scratch resistant surface which increases the wear life of the rod, rod bushing, and rod seal. The result is increased cycle life on all cylinders and improved sealability on hydraulic cylinders.

## PISTON ROD THREADS

Rods are stocked with both fine and coarse male threads as listed in the ordering procedure. Almost any special thread – female, metric, etc. – can be produced to customer requirements in just a day or so for a modest extra charge.

- Female thread depth: #10, 1/4, 5/16, 3/8 threads are 5/8 deep.  
1/2, 5/8, 3/4 threads are 1 1/4 deep.
- Threads smaller than the nominal rod diameter will be per the photo unless otherwise noted.

## PIVOT BUSHING

All HB2 caps have a stainless steel pivot bushing.

## STOP TUBE

Stop tubes are spacers between the piston and the cylinder head which prevent the piston from fully extending. This will reduce the bearing loads by increasing the distance between bearing points. Stop tubes should be used on long stroke cylinders and on cylinders where side load is a concern. See ordering procedure for available lengths. Also consider SMA aluminum cylinders for long strokes and side load conditions.

## ADJUSTABLE CUSHIONS

Reduce noise and decelerate the piston at the end of stroke. Aurora's cup type cushion seal provides positive cushioning yet allows a high flow rate when reversing for minimum cycle time. A stainless steel metering screw offers simple adjustment of the cushion rate. The adjusting screw is fully recessed and self locking on 1 1/2 and 2" bore cylinders. The adjusting screw on 1 1/8" bore cylinders is locked in place by a low profile nut.

SHOCK PADS



ROD WIPERS

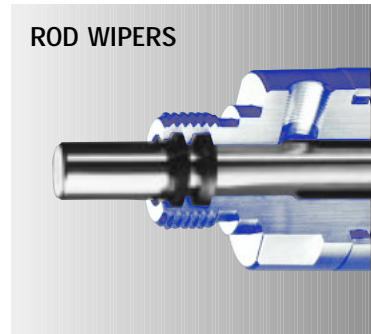

FEMALE ROD THREADS

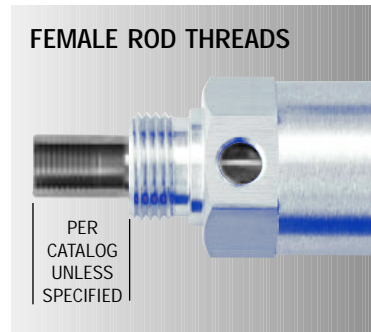

SPECIAL DIAMETER MALE THREADS

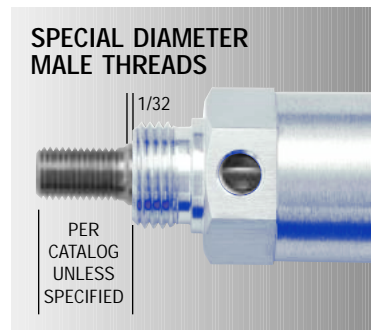

PIVOT BUSHING

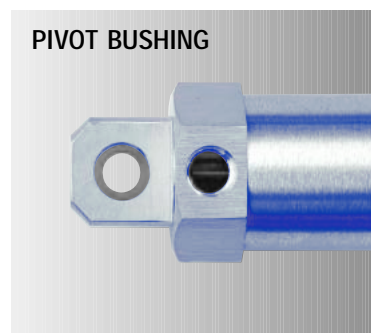

\* Polypak is a registered trademark of Parker Hannifin

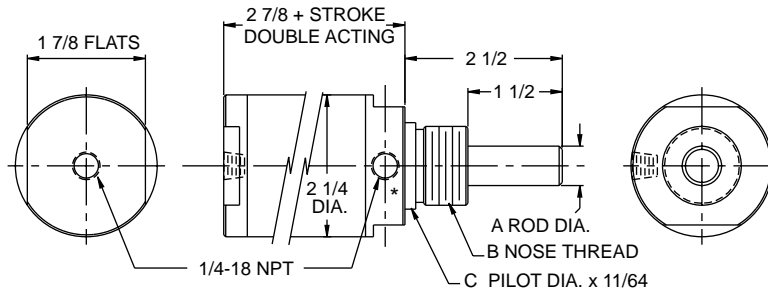

**HB1**

\* INDICATES CUSHION SCREW LOCATION AND AVAILABILITY.

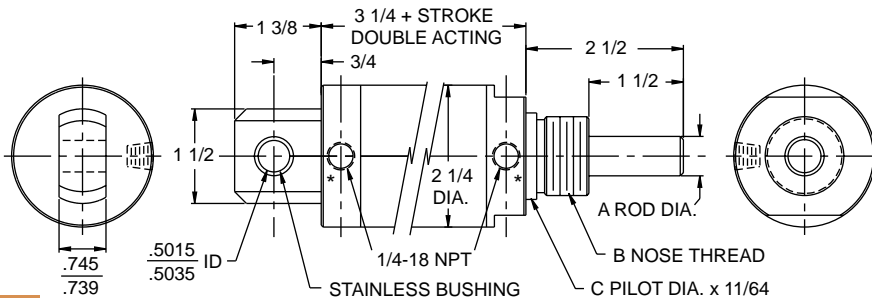

**HB2**

\* INDICATES CUSHION SCREW LOCATION AND AVAILABILITY.

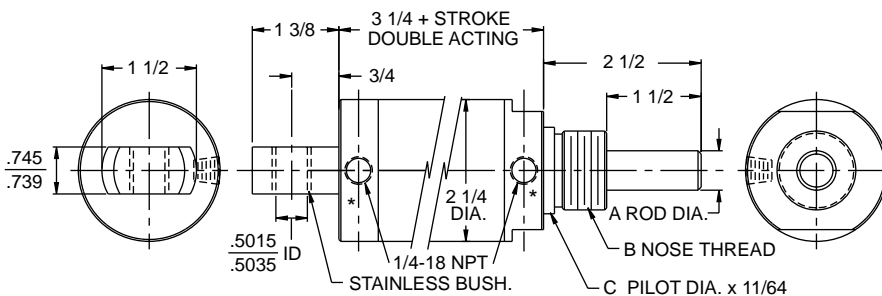

**HB29**

\* INDICATES CUSHION SCREW LOCATION AND AVAILABILITY.

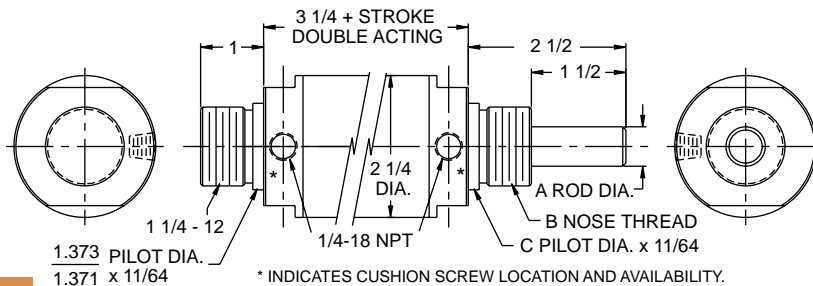

**HB3**

\* INDICATES CUSHION SCREW LOCATION AND AVAILABILITY.

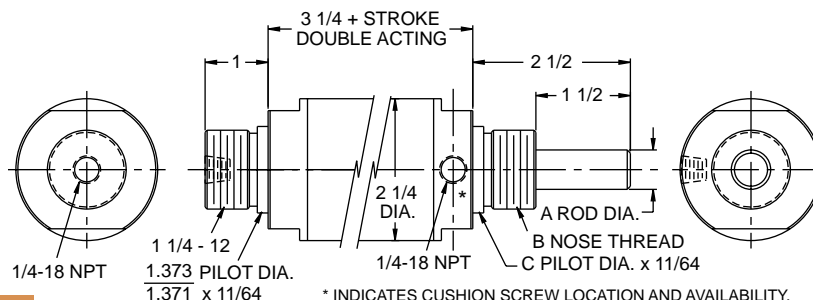

**HB4**

\* INDICATES CUSHION SCREW LOCATION AND AVAILABILITY.

## Single Acting Cylinders

Pneumatic only Adds to cylinder length

TYPE	STROKE	Add to cyl. O.A.L.	STROKE	Add to cyl. O.A.L.
Spring return	0-2"	1 1/2"	2 1/8"-4"	3"
Spring extend	0-2"	1 1/2"	2 1/8"-4"	3"

Spring Force: Spring fully extended approx. 20#  
Spring fully compressed approx. 75#

## Wrench Flats Optional

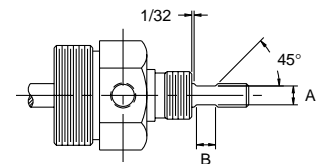

ROD DIA.	A	B
5/8	.500	3/8
3/4	.625	3/8

## 1 1/4-12 Nut Nose Mounting Nut

Not included with Cylinder Order separately

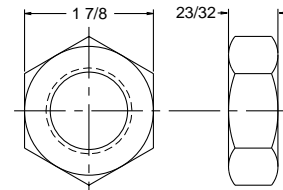

Thread 1 1/4 -12

Zinc plated steel

## HB-625 5/8-18 Thread

## HB-750 3/4-16 Thread

## Rod Clevis and Nut

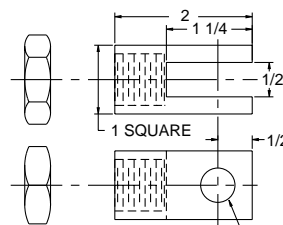

Zinc plated steel

## HB-601

## Clevis Pin Assembly

Used on HB-625, 750



Cushions not available on cylinders with 3/4" diameter rod.

A ROD DIA.	B NOSE THREAD	C PILOT DIA. COMBINATIONS	Part No. Code
5/8 Standard	1 1/4 -12	1.373/1.371	D
3/4 Oversize	1 1/4 -12	1.373/1.371	E

### HB Options

- Shock Pads
- Wrench Flats
- Rod Wiper
- Viton or Long Life Seals
- Polypak Rod Seal
- Chrome Rod
- Magnetic Piston
- Stop Tube
- Adjustable Cushions

#### HB-60

##### Flange Bracket

Order 1 1/4-12 nut separately  
Zinc plated steel

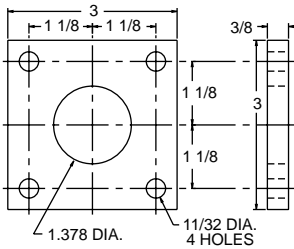

#### HB-80

##### Foot Bracket

Order 1 1/4-12 nut separately  
Zinc plated steel

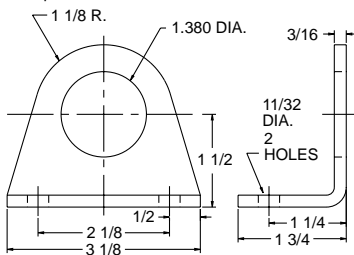

#### HB-100

##### Clevis Bracket

Used on HB2, 29  
Zinc plated steel

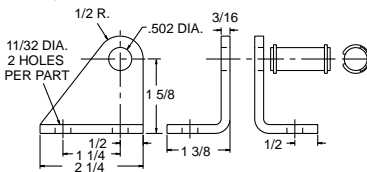

#### HB-100T

##### Trunnion Bracket

Used on HB7, 8, 9  
Zinc plated steel

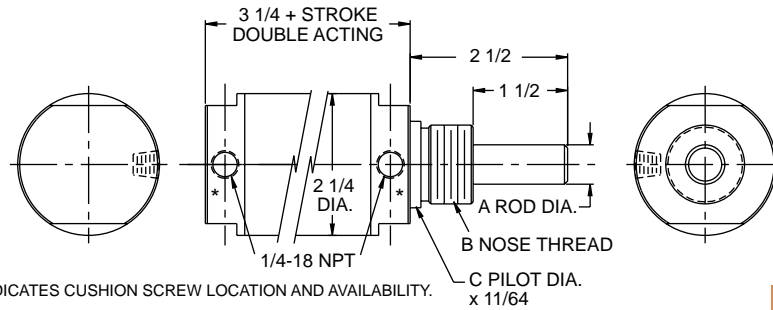
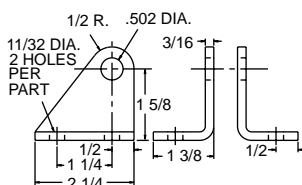

\* INDICATES CUSHION SCREW LOCATION AND AVAILABILITY.

HB5

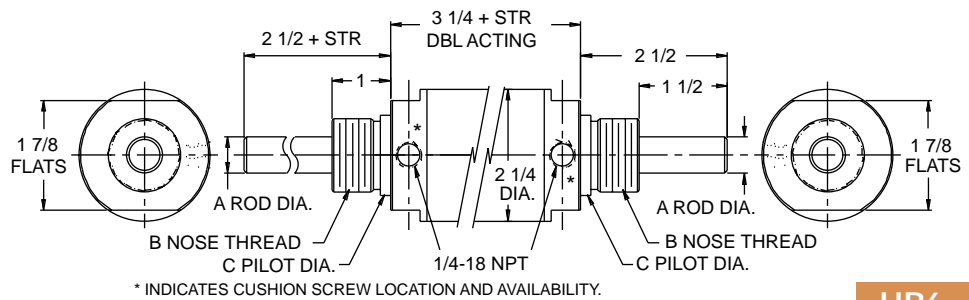

\* INDICATES CUSHION SCREW LOCATION AND AVAILABILITY.

HB6

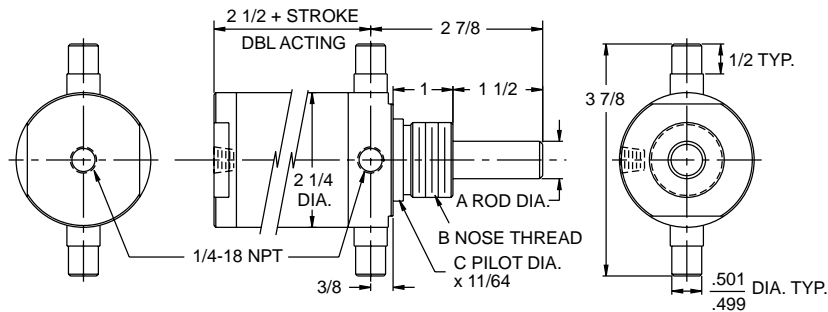

HB7

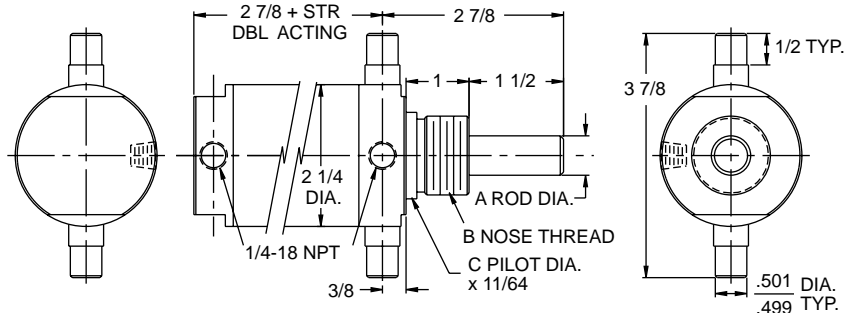

HB8

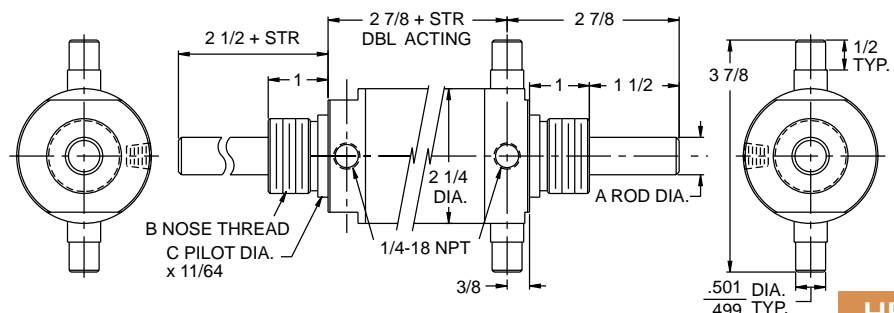

HB9

A ROD DIA.	B NOSE THREAD	C PILOT DIA. COMBINATIONS	Part No. Code
5/8 Standard	1 1/4 -12	1.373/1.371	D
3/4 Oversize	1 1/4 -12	1.373/1.371	E

# 2" BORE HB BRASS

200 PSI MAX. AIR  
400 PSI MAX. HYD. Non shock

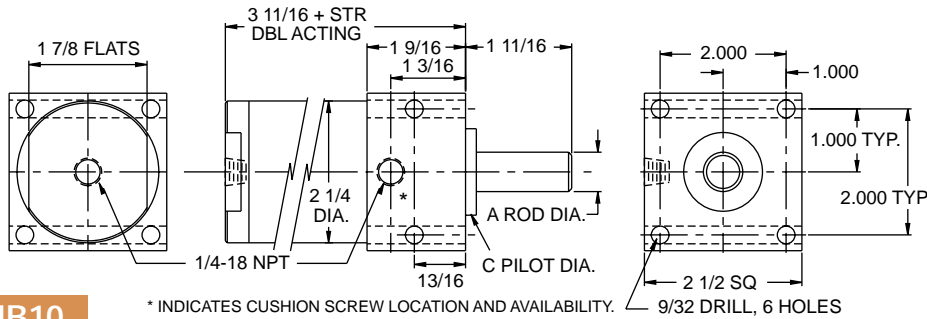

**HB10**

\* INDICATES CUSHION SCREW LOCATION AND AVAILABILITY.

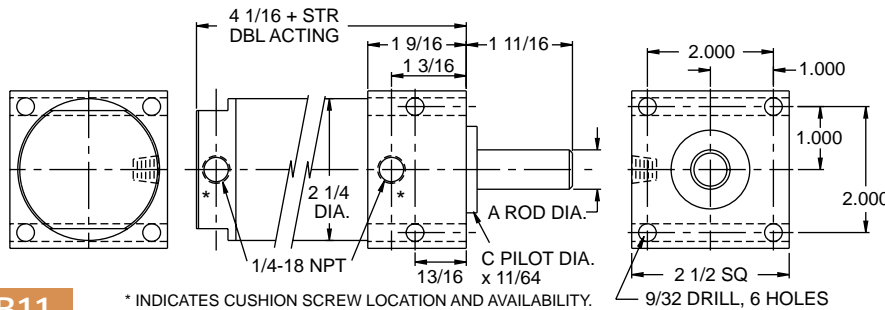

**HB11**

\* INDICATES CUSHION SCREW LOCATION AND AVAILABILITY.

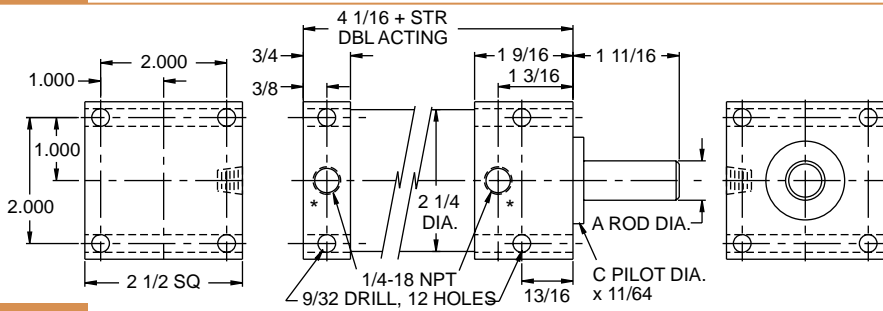

**HB12**

\* INDICATES CUSHION SCREW LOCATION AND AVAILABILITY.

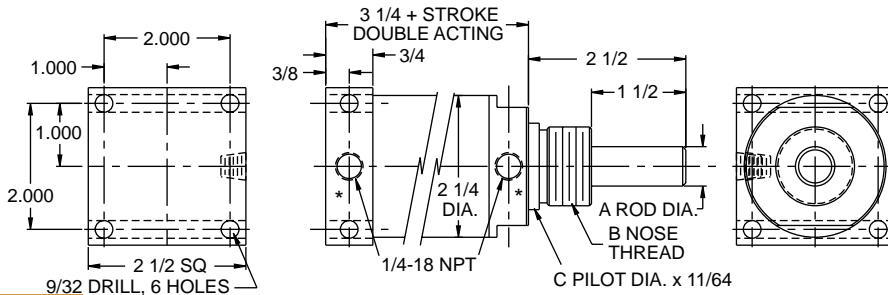

**HB13**

\* INDICATES CUSHION SCREW LOCATION AND AVAILABILITY.

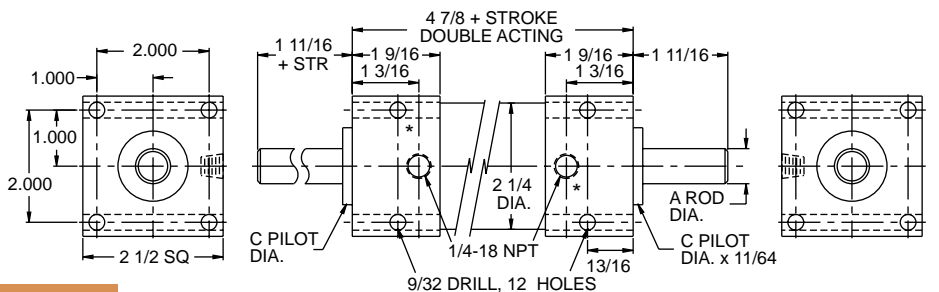

**HB14**

\* INDICATES CUSHION SCREW LOCATION AND AVAILABILITY.

A ROD DIA.	B NOSE THREAD	C PILOT DIA. COMBINATIONS	Part No. Code
5/8 Standard	1 1/4 -12	1.373/1.371	D
3/4 Oversize	1 1/4 -12	1.373/1.371	E

## Single Acting Cylinders

Pneumatic only Adds to cylinder length

TYPE	STROKE	Add to cyl. O.A.L.	STROKE	Add to cyl. O.A.L.
Spring return	0-2"	1 1/2"	2 1/8"-4"	3"
Spring extend	0-2"	1 1/2"	2 1/8"-4"	3"

Spring Force: Spring fully extended approx. 20#  
Spring fully compressed approx. 75#

## Wrench Flats Optional

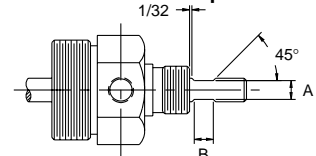

ROD DIA.	A	B
5/8	.500	3/8
3/4	.625	3/8

## HB-625 5/8-18 Thread

## HB-750 3/4-16 Thread

## Rod Clevis and Nut

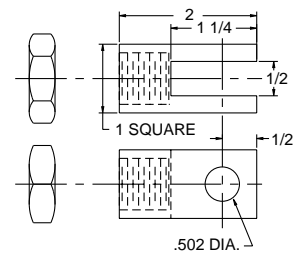

Zinc plated steel

## HB-601

## Clevis Pin Assembly

Used on HB-625, 750



## Problem:

## Side Load

## Solution:

**Series SMA with Wear Strip Piston and Teflon Rod Bushing**

# ORDERING PROCEDURE HB Brass

Select code numbers/letters (**bold type**) from each of the six boxes below - then select any options desired from the opposite page. List codes in the same sequence as shown.

The cylinder part number is an alpha numeric code.

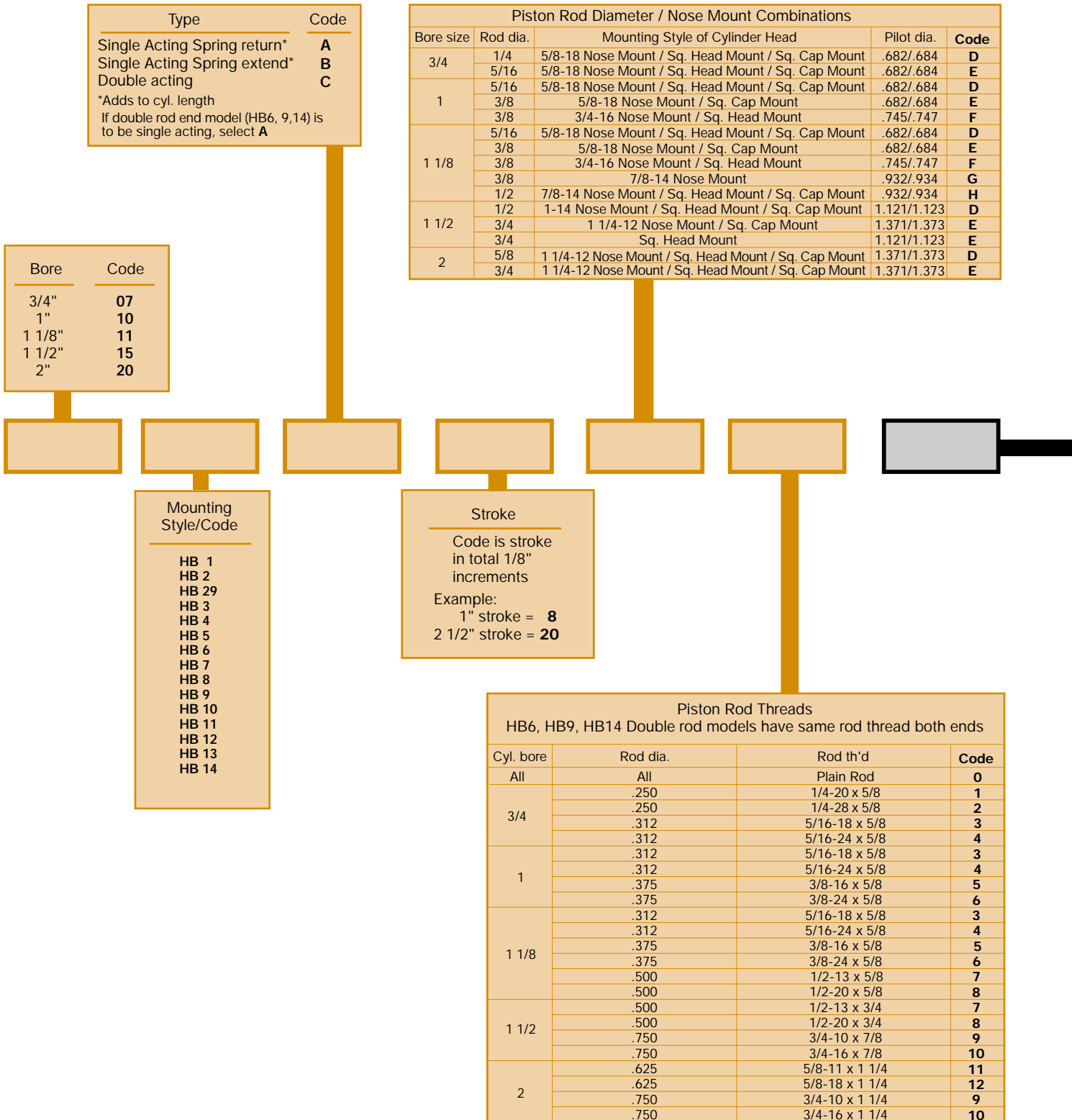

## Series HB cylinder options

List codes in the same sequence as they appear below

Option	Description	Code
Extra rod extension	Specify code letter <b>J</b> followed by the extra length as a two place decimal. Example: <b>J.50</b> = 1/2" extra <b>J1.25</b> = 1 1/4" extra HB6, 9, 14 double rod cylinders with extra extension cannot be ordered by a standard part number - consult factory for a special part number.	<b>J</b>
Wrench flats	Specify if required If specified will be added to both ends of HB6, HB9, HB14 double rod cylinders	<b>K</b>
Shock pads	Available on both ends of double acting cylinders and the end opposite the spring on single acting cylinders. Each pad adds 1/4" to cylinder length. Pneumatic use only to 180° F	Pad on rod end only
		Pad on cap end only
		Pads on both ends
Rod wiper	3/4", 1" bore - Not available 1 1/8" bore - Available only with 3/8" rod, 7/8 - 14 nose mount 1 1/2, 2" bore - Available all models - standard with trunnion & adj. cushion heads	<b>P</b>
Optional seal compounds	St'd seals are buna (nitrile) and require no code -40 to +200° F Long life available for extended cycle life +10 to +200° F Viton available for temps -10 to +400° F	<b>Q</b>
		<b>R</b>
Polypak rod seal	For optimum sealing on hydraulic cylinders Available only in 1 1/2 and 2" bore sizes	<b>S</b>
Hard chromed rod	Hard chrome plated steel - 100,000 min. yield	<b>T</b>
Magnetic piston	Not available in 1" bore Adds 1/2" to cylinder length	<b>W</b>
Hollow piston rod	Available in 5/16 dia. rod - thru hole .135" Available in 3/8 dia. rod - thru hole .248"    Not available on hard chrome rods Available in 1/2 dia. rod - thru hole .313"	<b>X</b>
Stop tube	Available on 1 1/2 & 2" bore only in 2" increments Specify code <b>Y</b> followed by length in inches Example: <b>Y4</b> = 4" stop tube Adds to cylinder length. An 8" stroke cyl. with 2" stop tube will be as long as a 10" stroke cylinder. Order actual stroke req. (8" above)	<b>Y</b> Not avail. HB6, 9, 14 or with adj. cushions
Oversize ports	1/4 NPT ports on 1 1/2 bore cylinder (both ends)	<b>Z</b>
Adjustable Cushions	Available on 1 1/8, 1 1/2, 2" bore except as follows: Mounting styles HB7, 8, 9 Rear port cap on mt'g styles HB1, 4, 10 Cyl. with 1/2" or 3/4" oversize rods or oversize ports Cylinders with shock pads	Cushion head end only
		Cushion cap end only
		Cushion both ends

### Part No. Example:

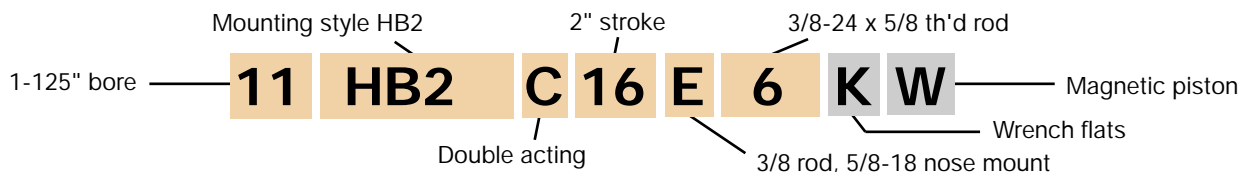

# HB Brass SERVICE PARTS

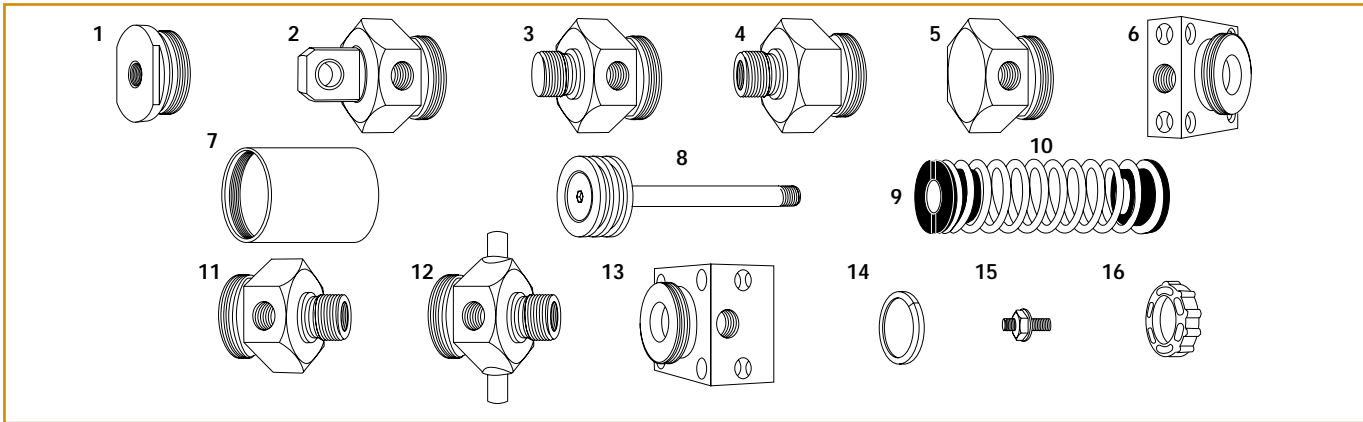

## 3 / 4 " B o r e S e r v i c e P a r t s

Key	Description	Part Number
	Seal Kit, Buna	07522-B
	Seal Kit, Long life	07522-LL
	Seal Kit, Viton	07522-V
1	Rear port cap	07503
2	Rear pivot cap	07506
2	90° Rear pivot cap	0750690
3	Rear stud cap	07507
4	Cap	07508
5	Cap	07509
6	Cap	07525
7	Tube - P.N. is T followed by the complete cyl. part no.	
8	Rod - P.N. is PR followed by the complete cyl. part no.	

Key	Description	Part Number
9	Spring stop 1/4" rod pair	07512-250
9	Spring stop 5/16" rod pair	07512-312
10	Spring - Must supply cyl. stroke	07515
11	Head 1/4 rod	07510-250
11	Head 5/16 rod	07510-312
12	Head 1/4 rod	07510-250 TRN
12	Head 5/16 rod	07510-312 TRN
13	Head 1/4 rod	07524-250
13	Head 5/16 rod	07524-312
14	Magnet pair	SS3207
16	Shock pad	75MSP

## 1 " B o r e S e r v i c e P a r t s

Key	Description	Part Number
	Seal Kit, Buna	10022-B
	Seal Kit, Long life	10022-LL
	Seal Kit, Viton	10022-V
1	Cap	10003
2	Cap	10006
2	90° Cap	1000690
3	Cap	10007
4	Cap	10008
5	Cap	10009
6	Cap	10025
7	Tube - P.N. is T followed by the complete cyl. part no.	
8	Rod - P.N. is PR followed by the complete cyl. part no.	

Key	Description	Part Number
9	Spring stop 5/16" rod pair	10012-312
9	Spring stop 3/8" rod pair	10012-375
10	Spring	10015
11	Head 5/16 rod, 5/8 - 18 nose	10010-312-625
11	Head 3/8 rod, 5/8 - 18 nose	10010-375-625
11	Head 3/8 rod, 3/4 - 16 nose	10010-375-750
12	Head 5/16 rod, 5/8 - 18 nose	10010-312TRN
12	Head 3/8 rod, 5/8 - 18 nose	10010-375TRN
13	Head 5/16 rod	10024-312
13	Head 3/8 rod	10024-375

## 1 1 / 8 " B o r e S e r v i c e P a r t s

Key	Description	Part Number
	Seal Kit, Buna, 5/16 rod	11222-312B
	Seal Kit, Buna, 3/8 rod	11222-375B
	Seal Kit, Buna, 1/2 rod	11222-500B
	Seal Kit, Long life, 5/16 rod	11222-312LL
	Seal Kit, Long life, 3/8 rod	11222-375LL
	Seal Kit, Long life, 1/2 rod	11222-500LL
	Seal Kit, Viton, 5/16 rod	11222-312V
	Seal Kit, Viton, 3/8 rod	11222-375V
	Seal Kit, Viton, 1/2 rod	11222-500V
1	Cap	11203
2	Cap Add suffix C for cushion	11206
2	90° Cap Add suffix C for cushion	1120690

Key	Description	Part Number
10	Spring 0 - 2 1/2" Stroke	11215
10	Spring Over - 2 1/2" Stroke	10015
11	Head, 5/16 Rod, 5/8 - 18 Nose	11253-312-625
11	Head, 5/16 Rod, 5/8 - 18 Nose, Cushion	11253-312-625C
11	Head, 3/8 Rod, 5/8 - 18 Nose	11253-375-625
11	Head, 3/8 Rod, 5/8 - 18 Nose, Cushion	11253-375-625C
11	Head, 3/8 Rod, 3/4 - 16 Nose	11253-375-750
11	Head, 3/8 Rod 3/4 - 16 Nose, Cushion	11253-375-750C
11	Head, 3/8 Rod 7/8 - 14 Nose	11253-375-875
11	Head, 3/8 rod, 7/8 - 14 nose, cushion	11253-375-875C
11	Head, 3/8 rod, 7/8 - 14 nose, wiper	11253-375-875W
11	Head, 1/2 rod, 7/8 - 14 nose	11253-500-875



## 1 1/8" Bore Service Parts (Cont.)

Key	Description	Part Number
3	Cap Add suffix C for cushion	11207
4	Cap	11208
5	Cap Add suffix C for cushion	11209
6	Cap Add suffix C for cushion	11225
7	Tube - P.N. is T followed by the complete cyl. P.N.	
8	Rod - P.N. is PR followed by the complete cyl. P.N.	
9	Stop 5/16 rod, 0 - 2 1/2" stroke	11212-312
9	Stop 5/16 rod, over 2 1/2" stroke (pair)	10012-312
9	Stop 3/8 rod, 0 - 2 1/2" stroke	11212-375
9	Stop 3/8 rod, over 2 1/2" stroke (pair)	10012-375
9	Stop 1/2 rod, 0 - 2 1/2" stroke	11212-500
9	Stop 1/2 rod, over 2 1/2" stroke (pair)	10012-500

Key	Description	Part Number
12	Head, 5/16 rod, 5/8 - 18 nose	11253-312TRN
12	Head, 3/8 rod, 5/8 - 18 nose	11253-375TRN
12	Head, 1/2 rod, 7/8 - 14 nose	11253-500 TRN
13	Head, 5/16 rod	11224-312
13	Head, 5/16 rod, cushion	11224-312C
13	Head, 3/8 rod	11224-375
13	Head, 3/8 rod, cushion	11224-375C
13	Head, 1/2 rod	11224-500
14	Magnet pair	SMS5911
15	Screw ass'y Add suffix V for Viton	11227
16	Shock pad	11 MSP

## 1 1/2" Bore Service Parts

Key	Description	Part Number
Add suffix HYD to seal kit part no. if polypak hyd. rod seal is required		
	Seal Kit, Buna, 1/2 rod	15022-500B
	Seal Kit, Buna, 3/4 rod	15022-750B
	Seal Kit, Longlife, 1/2 rod	15022-500LL
	Seal Kit, Longlife, 3/4 rod	15022-750LL
	Seal Kit, Viton, 1/2 rod	15022-500V
	Seal Kit, Viton, 3/4 rod	15022-750V
1	Cap	15003
1	Cap 1/4" port	15003250
2	Cap add suffix C for cushion	15006
2	Cap 1/4" port	15006250
2	90i Cap add suffix C for cushion	1500690
2	90i Cap 1/4" port	1500690250
3	Cap add suffix C for cushion	15007
3	Cap 1/4" port	15007250
4	Cap	15008
4	Cap 1/4" port	15008250
5	Cap add suffix C for cushion	15009
5	Cap 1/4" port	15009250
6	Cap add suffix C for cushion	15025
6	Cap 1/4" port	15025250
7	Tube - P.N. is T followed by the complete cyl. part no.	
8	Rod - P.N. is PR followed by the complete cyl. part no.	
9	Stop, 1/2 rod, st'd pair	15012-500
9	Stop, 1/2 rod, spring extend over 2" str.	15012-500L
9	Stop 3/4 rod, st'd pair	15012-750
9	Stop 3/4 rod, spring extend over 2" str.	15012-750L

Key	Description	Part Number
10	St'd spring	15015
10	Spring, over 2" spring extend only	15015L
11	Head, 1/2 rod	15010-500
11	Head, 1/2 rod, 1/4 port	15010-500250
11	Head, 1/2 rod, wiper	15010-500W
11	Head, 1/2 rod, 1/4 port, wiper	15010-500250W
11	Head, 1/2 rod, cushion	15010-500C
11	Head, 3/4 rod	15010-750
11	Head, 3/4 rod, 1/4 port	15010-750250
11	Head, 3/4 rod, wiper	15010-750W
11	Head, 3/4 rod, 1/4 port, wiper	15010-750250W
12	Head, 1/2 rod	15010-500TRN
12	Head, 3/4 rod	15010-750TRN
12	Head, 1/2 rod, 1/4 port	15010-500250TRN
12	Head, 3/4 rod, 1/4 port	15010-750250TRN
13	Head, 1/2 rod	15024-500
13	Head, 1/2 rod, 1/4 port	15024-500250
13	Head, 1/2 rod, wiper	15024-500W
13	Head, 1/2 rod, 1/4 port, wiper	15024-500250W
13	Head, 1/2 rod, cushion	15024-500C
13	Head, 3/4 rod	15024-750
13	Head, 3/4 rod, 1/4 port	15024-750250
13	Head, 3/4 rod, wiper	15024-750W
13	Head, 3/4 rod, 1/4 port, wiper	15024-750250W
14	Magnet pair	SS3215
16	Shock pad	15MSP

## 2" Bore Service Parts

Key	Description	Part Number
Add suffix HYD to seal kit part no. if polypak hyd. rod seal is required		
	Seal Kit, Buna, 5/8 rod	20022-625B
	Seal Kit, Buna, 3/4 rod	20022-750B
	Seal Kit, Long life, 5/8 rod	20022-625LL
	Seal Kit, Long life, 3/4 rod	20022-750LL
	Seal Kit, Viton, 5/8 rod	20022-625V
	Seal Kit, Viton, 3/4 rod	20022-750V
1	Cap	20003
2	Cap add suffix C for cushion	20006
2	90i Cap add suffix C for cushion	2000690
3	Cap add suffix C for cushion	20007
4	Cap	20008
5	Cap add suffix C for cushion	20009
6	Cap add suffix C for cushion	20025
7	Tube - P.N. is T followed by the complete cyl. part no.	
8	Rod - P.N. is PR followed by the complete cyl. part no.	
9	Stop, 5/8 rod, st'd pair	20012-625
9	Stop, 5/8 rod, spring extend over 2" str.	20012-625L

Key	Description	Part Number
9	Stop, 3/4 rod, st'd pair	20012-750
9	Stop, 3/4 rod, spring extend over 2" str.	20012-750L
10	St'd spring	20015
10	Spring Over - 2" spring extend only	20015L
11	Head, 5/8 Rod	20010-625
11	Head, 5/8 Rod, wiper	20010-625W
11	Head, 5/8 Rod, Cushion	20010-625C
11	Head, 3/4	20010-750
11	Head, 3/4 Rod, wiper	20010-750W
12	Head, 5/8 Rod	20010-625TRN
12	Head, 3/4 Rod	20010-750TRN
13	Head, 5/8 Rod, wiper	20024-625
13	Head, 5/8 Rod, wiper	20024-625W
13	Head, 5/8 Rod, cushion	20024-625C
13	Head, 3/4 Rod	20024-750
13	Head, 3/4 Rod, wiper	20024-750W
14	Magnet pair	SS3220
16	Shock pad	2MSP